

35 0 40000 10

Installation, Commissioning and Operation

Hand Book for AGM-VRLA-Batteries

- Marathon L -
- Marathon T -
- Sprinter P -
- Powerfit -

TABLE OF CONTENTS

| | Page |
|--|------|
| EXIDE Technologies- Installation, Commissioning And Operation Hand Book | |
| 1. Delivery / reception | 4 |
| 2. Safety | 5 |
| 3. Storage | 6 |
| 4. Installation of batteries | 12 |
| 5. Commissioning | 15 |
| 6. Operation | 16 |
| 7. Recycling | 23 |

CONFIGURATION OF AN AGM-VALVE-REGULATED-LEAD-ACID-BATTERY

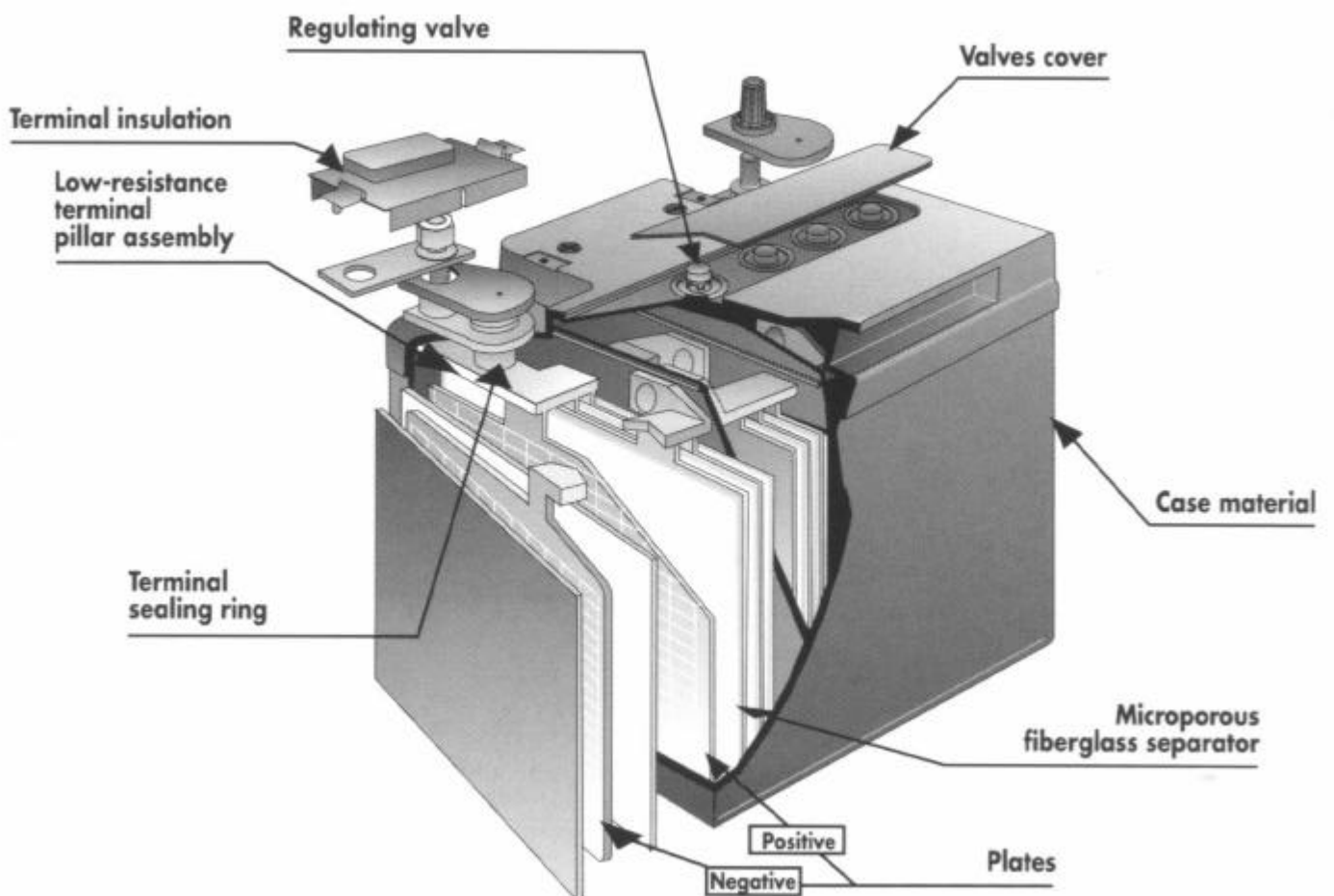

1. DELIVERY / RECEPTION

- EXIDE Technologies valve regulated batteries are delivered from our factories, Logistic Centres or via our distributors.
- The delivery items can be identified either by the number and type of cells / monoblocs or by referring to a battery drawing.
- Check the guarantee tape around the pallet for integrity.
- Do not stack the pallets.
- Observe the handling instruction stated on the packages.
- During transportation, take all precaution to avoid breaking those products which are considered to be „fragile“, and have been identified as being so on the package.
- If damage is found when unloading the goods, the carrier should be notified within 48 hours. Packings are guaranteed up to the delivery address written on the order. Damage coverage depends on the sales contract.

2. SAFETY

For any operation on the batteries, from storage to recycling, the following safety rules should be observed:

- Do not smoke.
- Use tools with isolated handles to tighten connections.
- Check that the connections between the cells / monoblocs are tight.
- Never place tools on the batteries (metal tools are particularly dangerous).
- Never lift the cells / monoblocs by the terminals.
- Never use a synthetic cloth or sponge to clean the casings.
- Avoid shocks.
- Even when disconnected, a battery remains charged.
- Always wear gloves.

3. STORAGE

In the users interest, for both the setup procedure and financial reasons, the storage period should be as short as possible.

3.1 The Premises

The storage premises should be designed so as to provide the following functions:

- Shelter the cells / monoblocs from bad weather and risk of flooding,
- Protect the batteries against any overheating risk induced by direct exposure to the sun radiation or by their amplification through glass walls,
- Protect the batteries from any risk of electric shock resulting from short-circuiting by a conductive object or from a building up of conductive dust,
- Avoid any risk of mechanical shock caused by dropping objects onto the cell / monobloc or by dropping the cell / monobloc itself.

3.2 Storage Conditions

- Temperature has an impact on the self-discharge performance. Hence, it is important to store the batteries in a fully charged condition in a cool but frost free place.
- Storage on a pallet wrapped in plastic material is authorized. It is not recommended however in rooms where the temperature fluctuates significantly, or when the relative humidity is such that condensation appears under the plastic cover. With time, this condensation can cause a whitish hydration on the poles. This hydration has no affect on the battery operation or service life.
- It is forbidden to stack the pallets when they are moved.
- Avoid storing unpacked cells / monoblocs on sharp-edged supports.

3.3 Storage Time

The lower the temperature, the lower the self-discharge. This means the battery can be stored longer between recharging operations.

Storage at different temperatures (5 year product)

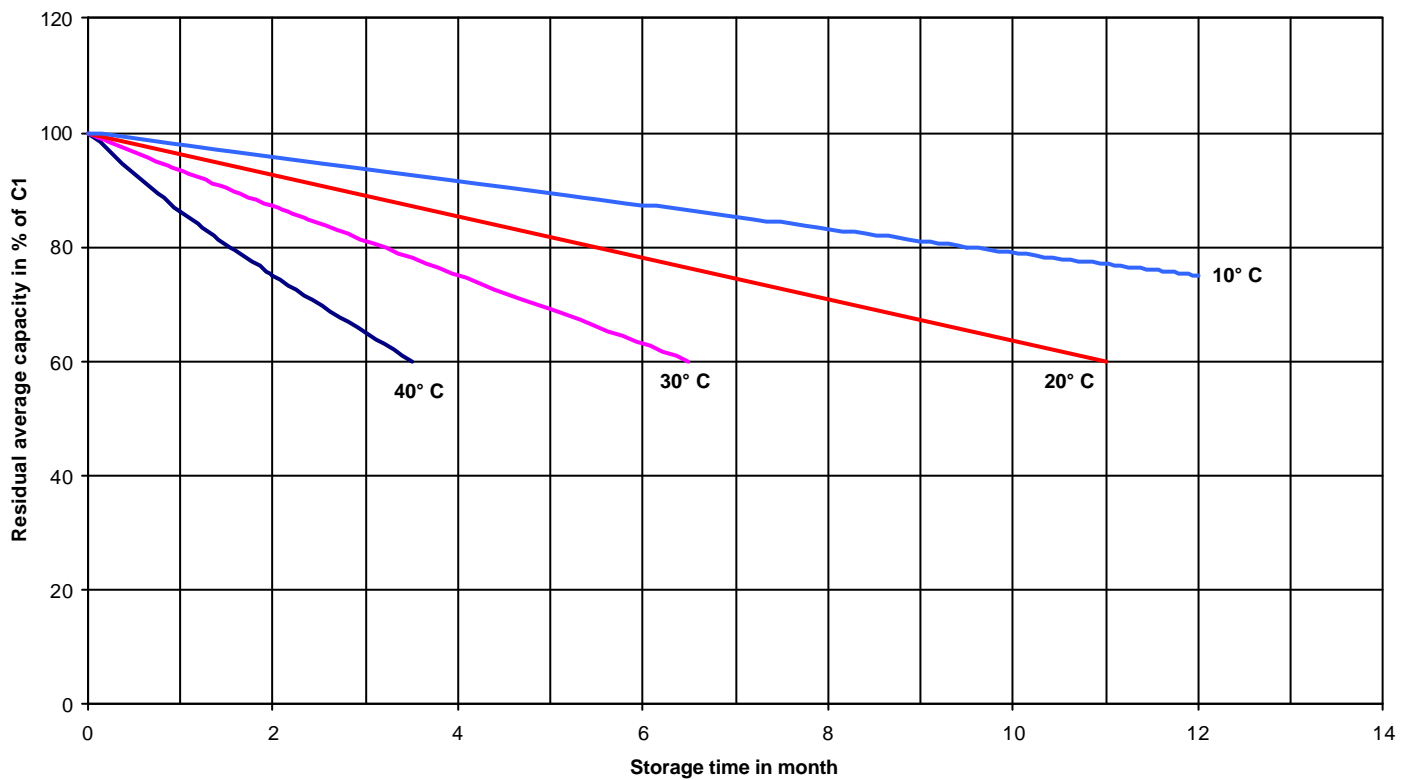

Storage at different temperatures (10 year product)

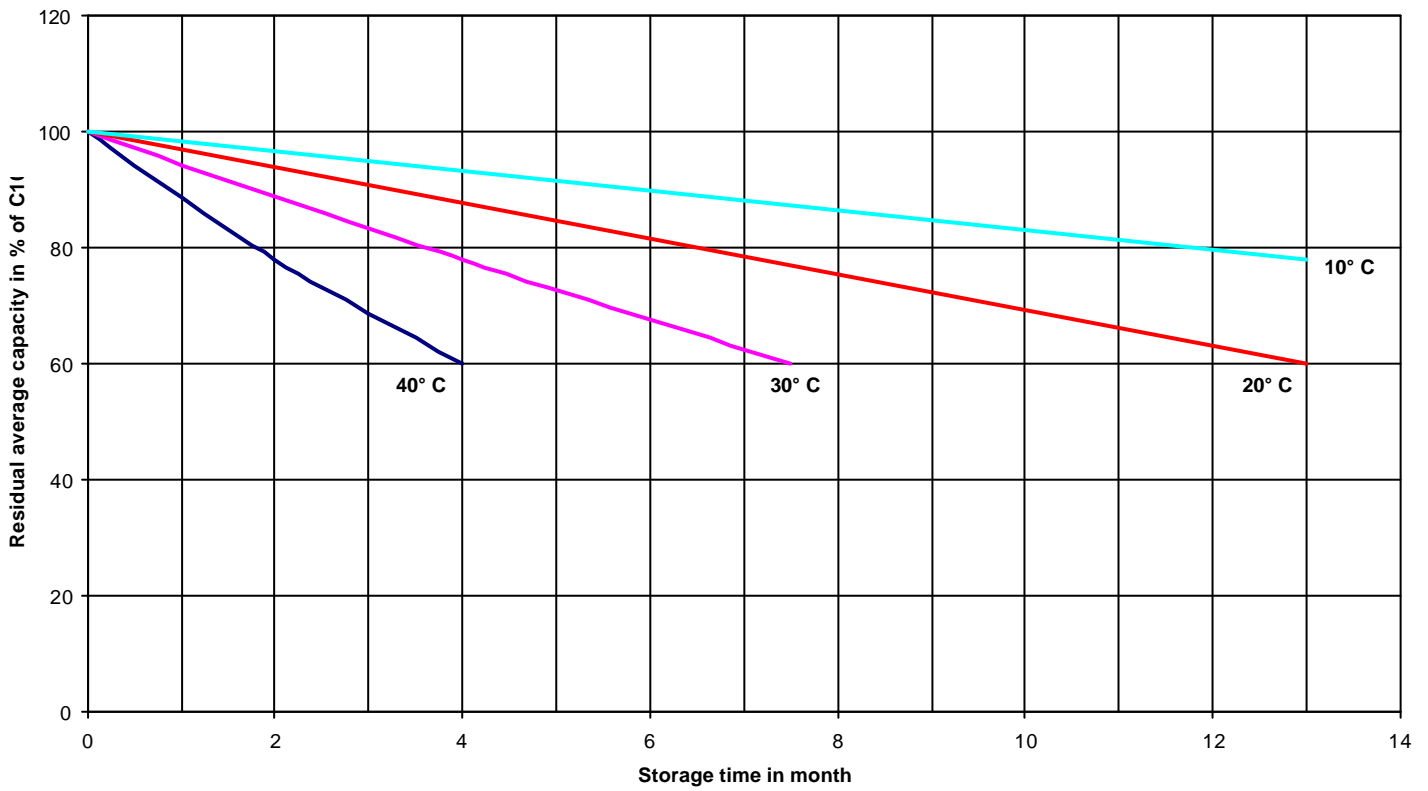

3.4 Maintenance for Battery Storage

- The premises in which the batteries are being stored must be clean and well maintained.
- Appropriate inventory turnover, based on a FIFO method, will result in a higher operating quality of the products.
- In the event of the battery casings needing to be cleaned, prior to their installation, never use solvents or abrasives. A detergent solution (diluted with water) may be used.
- For extended storage periods, it is recommended to check the „open-circuit“ voltage at the following intervals:
 - storage at 20° C: after a storage period of 6 months, then every 3 months afterwards
 - storage at 30° C: after a storage period of 4 months, then every 2 months afterwards.

A trickle charge* should be considered necessary when the voltage measured is below 2.06 volts.

*Trickle charge means continuous charge at a low rate, approximately equivalent to the internal losses of the battery and suitable to maintain the battery in a fully charged state.

- Trickle charge mode in storage

Constant-voltage charging

| Temperature | Max. voltage per cell | Min. voltage per cell | Max. current | Charging time at max. voltage |
|-------------|-----------------------|-----------------------|---------------------|-------------------------------|
| 20° C | 2.38 V | 2.27 V | 0.2 C ₁₀ | 24 h |
| 25° C | 2.35 V | 2.25 V | 0.2 C ₁₀ | 24 h |
| 30° C | 2.32 V | 2.22 V | 0.2 C ₁₀ | 24 h |

Depending on the chargers, the charging time shall be extended by 24 hours for every 0.04 volts under the maximum Voltage, the „minimum voltage“ being the lower limit.

Constant-current charging (15 to 30° C)

| Measured voltage | Current | Time at 20° C |
|------------------|----------------------|---------------|
| 2.05 V | 0.05 C ₁₀ | 14 hours |
| 2.06 V | 0.05 C ₁₀ | 13 hours |
| 2.07 V | 0.05 C ₁₀ | 12 hours |

For temperatures below 15 °C, it is recommended to charge the battery during 20 hours.

4. INSTALLATION OF BATTERIES

4.1 Preliminary Steps

- Check each cell / monobloc separately by measuring the open-circuit voltage.

| | |
|-------------------|--------------------|
| 2 Volt cell: | $U > 2.06$ Volts. |
| 6 Volt monobloc: | $U > 6.18$ Volts. |
| 12 Volt monobloc: | $U > 12.36$ Volts. |

- Check that the battery racks are stable and horizontal. For the shelf assemblies with 4 level of 2 rows or 5 levels of 3 rows, the assembly should be secured to the building.
- For the installations where EXIDE Technologies drawings are supplied, the cells / monoblocs should be mounted in accordance with these drawings.

- When batteries are being installed in metallic cabinets or on racks precautions must be taken to avoid the direct contact of terminals between surrounding metal parts and the connections (safety distance: 10 mm).
- The racks or cabinets should provide adequate ventilation, both upper and lower to allow the heat produced by the batteries and their charging system to escape. It is recommended to leave at least 5 mm between adjacent rows of batteries.
- The use of metal clamps on the cells / monoblocs is not recommended. A system made of insulating material should be used.
- The grounding of racks or cabinets should be performed in accordance with the laws relevant to the country of installation.
- The reference standards for the battery cabinet or equipment room are as follows: IEC 364-4, EN 50 091-1, IEC 896-2.

4.2 Assembly

- For assembly operations: use insulated tools. It is recommended to protect yourself by wearing insulating gloves, and to remove any metal objects such as watches or any other items of jewellery, especially in the case of installation in a cabinet (see also the paragraph relating to safety).
- Moderately lubricate the inserts and connections using silicone grease. The use of a petroleum-based lubricant is not recommended

- The connections should be tightened by means of a torque wrench, set to the following:

M6 connections: 6 ± 1 Nm
M8 connections: 8 ± 1 Nm
M12 connections: 25 ± 1 Nm
- Check the overall battery voltage: it should be consistent with the number of series connected cells / monoblocs.

4.3 Parallel Arrangements

- A parallel arrangement does not affect the installation reliability, it actually offers (in the event of a failure occurring on one string) the advantage of providing some standby autonomy from the remaining strings. In practice, an installation can consist of up to 5 strings. For larger arrangements, contact your EXIDE Technologies representative. Always connect the individual series strings first and check that the different strings are at the same potential before connecting them together.

5. COMMISSIONING

- For floating applications, commissioning after a storage period or assembly in accordance with the conditions specified above, consists merely of connecting the battery to its charging system.

The charging voltage should be adjusted in accordance with the specifications set out in paragraph 6.2.

The safety systems: fuses, circuit-breakers and voltage relays for battery isolation, are all tested independently.

- If a contractual endurance test is required, it is recommended initially, to maintain the batteries under floating voltage for 4 to 5 days. This will make up for the losses induced by storage, and improve the equalisation of the cells or monoblocs (for a 3-month storage period at 20° C).

6. OPERATION

6.1 Operation in Floating mode

- This operating mode is characterized by a permanent power supply to the battery. Hence, a low current is fed to the battery, maintaining it in a fully charged condition ready to cope with any demand.

6.2 Floating Voltage and Floating Current

- The RMS value of the floating current alternating component should be lower than 5A (RMS) / 100Ah nominal capacity. Beyond that value, the Joule effect induced by this alternating component significantly increases the battery temperature and therefore lowers its service life.
- The optimum adjustment of the floating voltage depends on the temperature. At 20° C, it is equal to 2.27 V/cell, at 25° C it will be equal to 2.25 V/cell. For applications where the temperature fluctuates significantly, it is recommended to serve the charging system voltage to the ambient temperature. In the case of installation in cabinets or in bays, the optimum temperature measurement is achieved at 2/3 of the probe placed in the center of this level.

In the case of voltage compensation, the voltage should be adjusted using the values indicated on the diagram below.

Charging voltage versus temperature

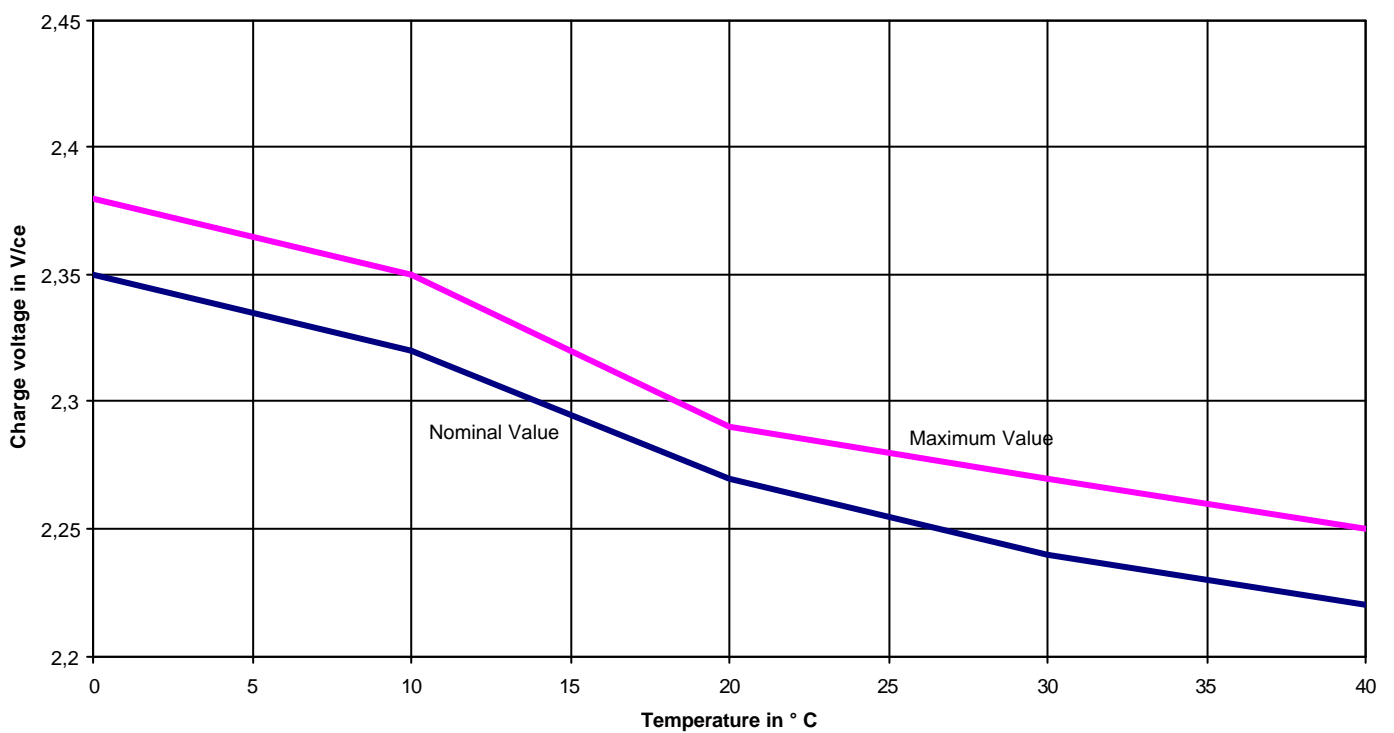

6.3 Charging Conditions

- The constant-voltage charging mode with limited current is the most appropriate to preserve a very long service life to the batteries. The tables below (Charts 1 and 2) give an informative value of the time required to recharge a battery under 2.27 or 2.40 V/cell at 20° C (2.25 V/cell or 2.38 V/cell at 25° C) according to its state of discharge and to the initial current limit.

A recharge with current values higher than those mentioned does not save much time, and could damage the battery. The recharges performed at voltages higher than 2.27 V/cell shall be limited in time.

Example on how to use the charts (Chart 1):

A battery discharged by 75% in operation under 2.27 V/cell at 20° C, with a rectifier capable of feeding a current of 0.2 C₁₀, recovers 90% of its capacity in approximately 6 hours.

Note: under 2.40 V/cell the current must not be higher than 0.2 C₁₀.

Charge in operation at constant voltage
with limited current, V=2.27 VPC at 20° C

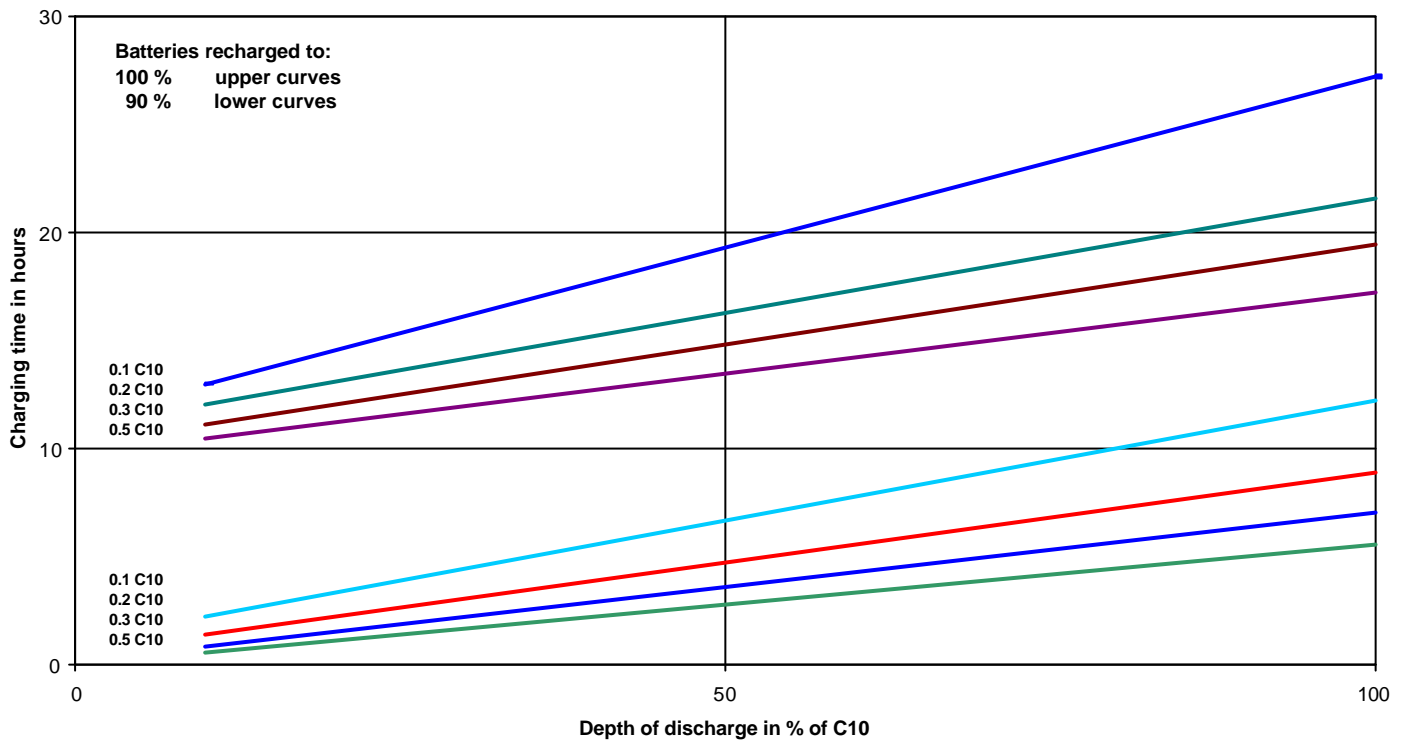

Charge in operation at constant voltage
with limited current, V=2.4 VPC at 20° C (Cycling)

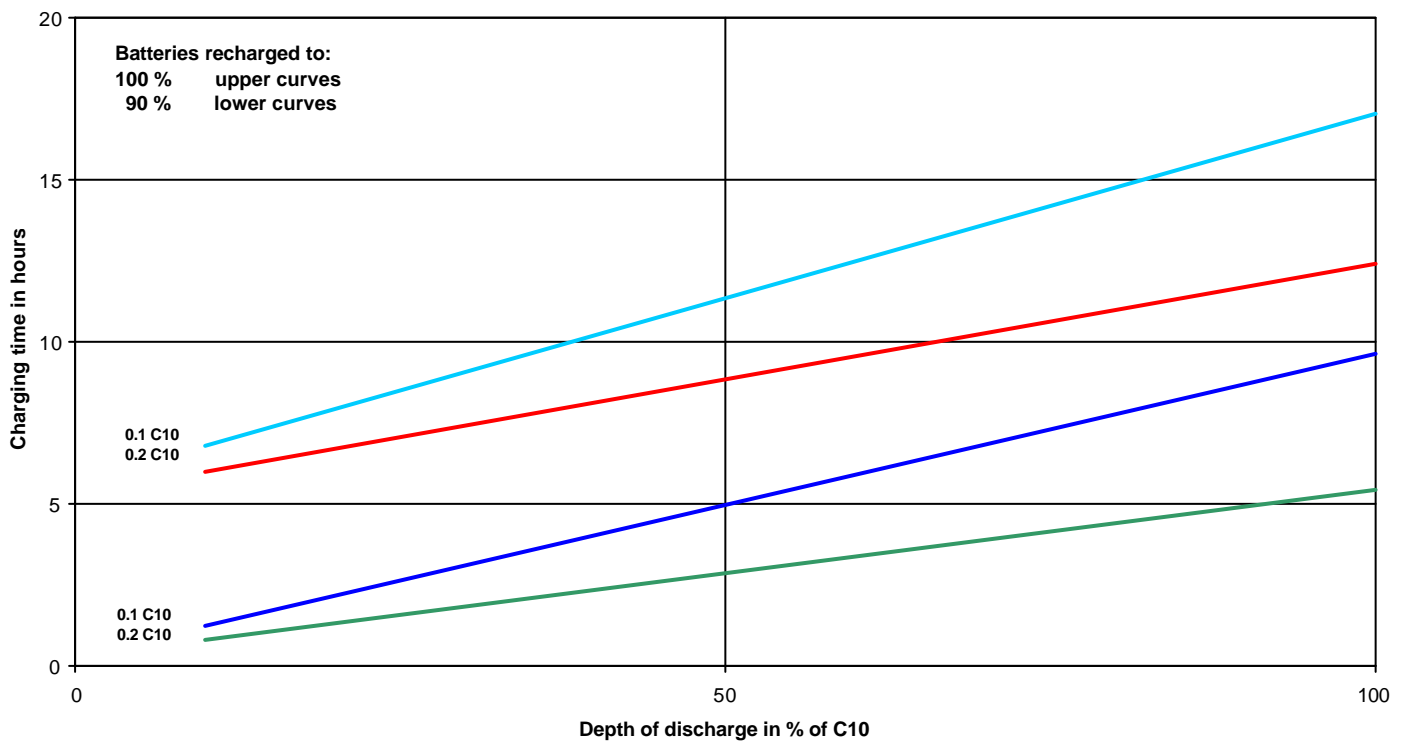

6.4 Behavior in Discharge

- The battery's service life can be affected by too many successive deep discharges. For this reason, the end-of-discharge voltage should be limited according to the discharge rate.

| Rate | Min. stop voltage per cell |
|-----------------|----------------------------|
| 5 to 60 minutes | 1.60V |
| 1 to 3 hours | 1.65V |
| 3 to 5 hours | 1.70V |
| 5 to 10 hours | 1.75V |
| Over 10 hours | Contact Manufacturer |

Note: the values given refer to a voltage level measured across the battery.

- For the system that can discharge at different rates (e.g. operating rate/standby rate), all measures should be taken to avoid deep discharge at a slow rate.

- The internal resistance is a critical parameter when computing the size batteries subjected to current peaks near the end of discharge. The internal resistance varies with the battery's state of charge, as shown on the chart below.

Internal resistance in relation to the state of charge

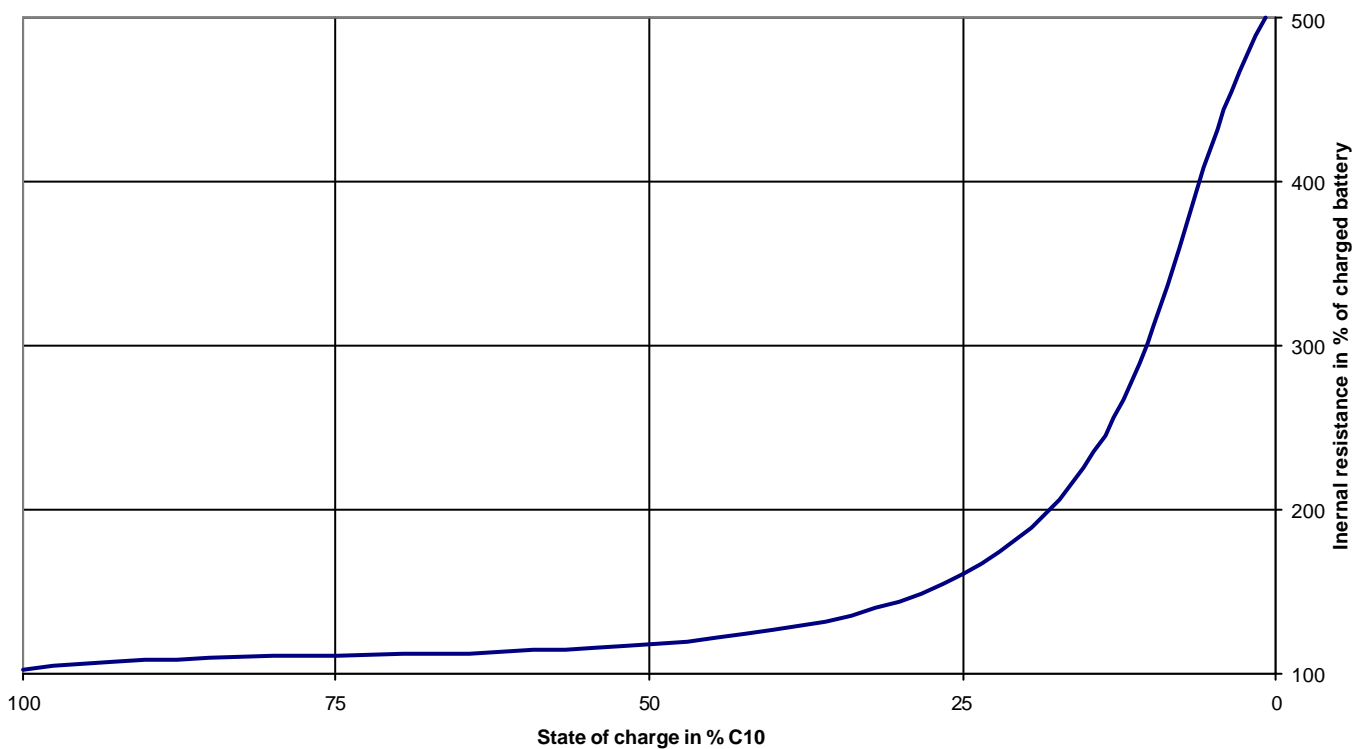

6.5 Influence of Temperature

- These AGM batteries are designed to operate within a temperature range between -15°C and $+50^{\circ}\text{C}$. Below -15°C , there is a risk of freezing the equipment. Yet, it is possible to use the batteries at lower temperatures, under specific conditions (contact your EXIDE Technologies representative). The use of VRLA batteries at high temperatures affects their service life. This service life is divided by two for a rise in temperature of 10°C . The optimum operating temperature is 20°C . Above 40°C , there is a risk of thermal runaway.
- The battery temperature affects the available capacity, as shown on the chart opposite. Above 35°C , the increase in capacity is insignificant.

Capacity versus Temperature

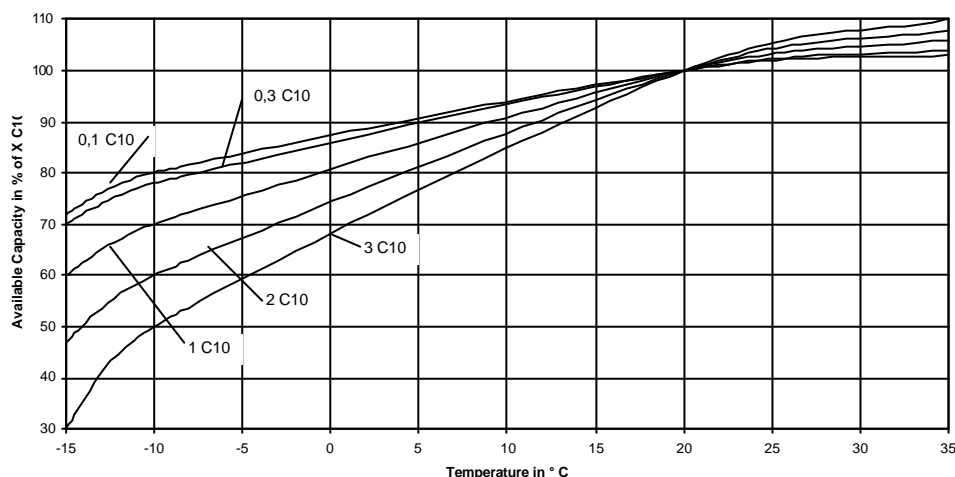

6.6 Inspections – Periodic

- Periodic inspections are designed to ensure that the charge voltage and current settings, the discharge stresses, the temperature levels, the storage conditions and other conditions comply with those set out at the beginning of the equipment's life. Furthermore, periodic discharges can be used to assess the available operating endurance, to detect faulty cells / monoblocs and ageing symptoms of the battery, in order to consider equipment replacement in due time. Maintenance instructions are supplied with the batteries.

7. RECYCLING

- Lead-acid batteries are recyclable products. Recognizing the need to be involved in the whole lifecycle of a battery and to protect the environment, EXIDE Technologies runs factories to refine used lead. Please contact your EXIDE Technologies representative who will advise you on this matter.

Important Notice: The manufacturer of batteries EXIDE Technologies do not take over responsibility for any royalties resulting from this paper or resulting from changing in the mentioned standards, neither for any different national standards which may exist and has to be followed by the installer, planner or architect.

EXIDE Technologies
Network Power
Im Thiergarten
63654 Büdingen (Hessen)
Phone: + 49 60 42 81 70
Fax: + 49 60 42 81 233
www.exide.com

State: 04/2002